

## FEATURES

- Engineering Unit Data Stream up to 5,000Hz (Samples/Channel/Second)
- Accuracy as low as  $\pm 0.04\%$  Full Scale
- 0 - 1,000psi Pressure Range
- Non-Multiplexed, Synchronous Scanning
- IEEE1588-2008v2 PTP Compliant
- TCP/IP or iDDS Communication Options
- 24-bit A/D Converter Per Channel
- Multi-Drop Architecture for Multiple Module Simplicity
- Dry Gas or All-Media / Liquid Measurement Configurations



From Left to Right: DSA5000 - Standard Gas, DSA5200 - All-Media, DSA5300 - Gas / iDDS with "QD" Header and Shock-Mount

## GENERAL DESCRIPTION

The DSA5000 pressure scanner is a versatile, all-in-one data acquisition system. Each DSA5000 uses a pressure sensor per input channel architecture. All data acquisition, data conversion, and communications are handled by integrated processors and A/D converters. The DSA5000 utilizes an individual 24-bit A/D converter and RTD for each sensor allowing fully synchronous, accurate, and fast data collection.

The DSA5000 is designed to output an engineering unit data stream over an Ethernet connection. A broad selection of data output formats and options are available including ASCII and Binary data using TCP, UDP, and FTP transport protocols. A Webserver is fully integrated providing an intuitive and easy means for configuration, operation, and data collection. An iDDS configuration is available for iDDS systems. All modules are Precision Time Protocol (IEEE-1588v2) compliant for time synchronization.

The DSA5000 was developed around the option to use a hardware multi-drop architecture through a proprietary Ethernet protocol called Scanivalve Synchronous Ethernet Protocol, or SSEP. This feature allows for a single Ethernet connection to a "master" DSA5000 which controls and collects data from other 5000 series modules in the network. Module identification, configuration, and synchronization happens seamlessly, minimizing setup time and frustration.

In addition to the electronics, several mechanical and interface options are available, including a large variety of pneumatic inputs, environmental add-ons, and integrated valving for on-condition calibrations and purging. The result of the careful design is a complete package that makes multi-point pressure acquisition simple and powerful.

## APPLICATIONS

The DSA5000 is a versatile scanner, designed for a wide range of applications. The rugged package, customizable pneumatic interface options, and configurability make it an ideal fit in applications such as gas turbine testing, flight testing, industrial, wind engineering, and others. The user-friendly interface, simple operation, and low overhead requirements also make it ideal for educational facilities, small research and development projects, automotive testing, and other quick tests with low channel counts.

The DSA5000 supports an extremely wide range of pressure inputs from 4"H<sub>2</sub>O (0.18psi) to 1,000psi in several pneumatic configurations. For harsh environments where the module may be subjected to moisture, all DSA5000 modules are IP67 rated. In cases where the module may experience shock or vibration, an optional bolt-on "shock mount kit" is available to provide continuous and reliable operation.

For applications that require an extended operating temperature range, the DSA5000 can be configured with an internal heater kit. This allows for year-round operations in open test cells, flight tests, elevated temperatures for Freon testing, and any other environment where temperature extremes, rapid or otherwise, are expected.

An "All-Media", or liquid version of the DSA5000 is available for applications looking to measure liquid based media, such as water, oil, fuel, vapor, and more. A bleed or fill valve is built in to each channel to fill lines and minimize air bubbles.

## CONFIGURATIONS

DSA5000 modules can be configured to specifically fit each unique application.

### Media Configurations

To meet pressure measurement needs in many applications, the DSA5000 can be manufactured in two media variations: Dry Gas or All-Media.

Dry Gas builds are designed to measure any compatible dry gas or air. Gas builds have unique features including:

- Differential or absolute transducers.
- Integrated calibration valve. This valve is “Normally Px,” where no control pressure defaults the valve to Measurement (Operate) mode. 90psi control pressure is required to change the DSA calibration valve into Purge, Calibrate, or Isolate mode. Each of these states can be established during a test with measurement pressure applied. Three internal solenoids are used to configure the logic state of the valve, fed by a single control supply input, and are controlled via software.
- Pneumatic configurations including standard or common differential, true-differential, individual reference, and dual-range.
- An optional “QD” or quick-disconnect input header. This allows for quick module or test article changes, or the flexibility to pre-plumb test models to the input header before the module is installed.



DSA5000 Gas shown with optional “QD” Px Header and Shock Mount Kit

All-Media or liquid builds are designed to handle a wide variety of compatible measurement media including water, oil, fuel, vapor, and more. All-media builds will have unique features including:

- Gauge or absolute transducers.
- Multiple ranges in a single unit.
- Integrated bleed or fill valve for each channel.
- No control pressure required (no built in calibration valve).
- Sealing compound options to support different media types.

### Pneumatic Interface Options

For convenience and flexibility, the DSA5000 offers a variety of interfacing options. All pneumatic inputs use a 5/16”x24 female thread matching the SAE J1926-1\* standard. Scanivalve supports this with a range of stainless steel tubulations, compression fittings, and quick-connect fittings, available for any DSA5000 configuration.

**Scanivalve**

## MECHANISMS

### Sensors

The DSA5000 was designed with accuracy and long-term sensor stability as a hallmark feature. Each sensor has an integrated RTD used for thermal compensation. Increasing the resolution of the sensor’s temperature while improving the temperature update rate allows the DSA5000 to perform extremely well over the entire compensated temperature range. The combination of high quality sensors, careful package design, excellent characterization, and improved thermal compensation provides unmatched, long-term stability. This stability allows for less frequent zero and span calibrations.

### Electronics

The electronics used in the DSA5000 offer several key advantages:

- One 24-bit A/D per pressure sensor per channel architecture. This allows fully synchronous data collection with no concessions or complications due to internal module timing.
- One RTD per pressure sensor. Each RTD utilizes its own 24-bit A/D converter for faster update rates and better temperature resolution and compensation.
- High-speed processors that allow for continuous engineering unit data output at up to 5,000 samples/channel/second.

### Environmental

The DSA5000 is designed for harsh environments. The DSA5000 in any configuration is IP67 rated with a rugged but lightweight aluminum case. To supplement this capability, a self-controlled internal heater can be installed. With the heater option installed, Gas DSA modules can be operated in ambient temperatures down to -60°C, whereas All-media builds are supported to -30°C. The DSA5000 can also be fitted with an optional shock-mount kit. This has been tested to MIL-STG 810G Cat. 24, 514.6.



\*SAE J1926-1 is equivalent to ISO 11926-1 for 5/16”x24 o-ring sealing straight thread fittings.

## SPECIFICATIONS

### Inputs (Px):

Female Threads: 5/16x24 (SAE J1926-1)  
 Tubulations: 0.040" (1.0mm), .063" (1.6mm) or 0.125" (3.2mm)  
 Compression: 1/16" and 1/8"  
 Quick-Connect: 1/16" Scanivalve QC

### Full Scale Ranges:

Differential: (Gas only) ±4 inch H<sub>2</sub>O, 10 inch H<sub>2</sub>O, 1, 2.5, 5, 15, 30, 50, 100, 250, 500, 600, 750, 1000 psid  
 (±1.25, 2.5, 7, 17, 35, 100, 205, 345, 690, 1724, 3450, 4125, 5175, 6895kPa)

Absolute: 15, 30, 50, 100 and 300 psia  
 (±100, 205, 345, 690, 2068kPa)

Gauge: (All-Media only) 1, 2.5, 5, 15, 30, 50, 100, 250, 500, 600, 750, 1000 psig  
 (7, 17, 35, 100, 205, 345, 690, 1724, 3450, 4125, 5175, 6895kPa)

### Accuracy\*:

Pressure Range	Gas (%F.S.)	All-Media (%F.S.)
4 inch H <sub>2</sub> O	±0.20	NA
10 inch H <sub>2</sub> O	±0.15	NA
1psi	±0.10	±0.15
2.5psi	±0.05	±0.08
5 to 500psi	±0.04	±0.06
501 to 1000psi	±0.05	±0.08
15 to 300 psia (w/CALB)	±0.04	±0.06

(Including linearity, hysteresis, and repeatability)

**Resolution:** 24-bit

**Communication:** Ethernet 1000baseT

### Communication Protocol:

TCP/IP, UDP, FTP, HTTP, SSEP (TCP Builds Only) IEEE1588-2008v2 PTP iDDS (optional)

**Standards:** CE, IP67, RoHS v3 MIL-STD-810G Cat. 24

**Max Scan Rate:** 5,000Hz (samples/ch/sec) EU

**External Trigger:** 6.5 mA at 4.5 Vdc minimum

**Weight:** (no input fittings)  
 Gas Base: 5.45 lbs. (2.47kg)  
 All-Media Base: 4.34 lbs. (1.97kg)  
 Heater: +0.10 lbs. (45g)  
 QD Header: +0.40 lbs. (181g)  
 Shock Mount Kit: +0.56 lbs. (255g)

**Operating Temperature:** 0°C to 70°C  
 Gas w/heater: -60°C to 70°C  
 All-Media w/heater: -30°C to 70°C

**Storage Temperature:** -30°C to 80°C

**Temperature Compensated Range:** 0°C to 72°C

**Total Thermal Error over 0 - 72°C Range:** Less than ±0.001% F.S. per °C

**Mating Connector Type:** Power: A-Code , 8-pin, M12  
 Ethernet: X-Code, 8-pin, M12  
 SSEP Enet: A-Code, 4-pin, M8

**Power Requirements:** Standard: 9-36Vdc @ 12W  
 With Heater: 24-36Vdc up to 180W

**Proof Pressure†:** 4 inch H<sub>2</sub>O to 1 psi = 8 psi  
 2.5 to 499 psid = ~2.0x  
 500 to 1000 psid = 1250psi

**Burst Pressure†:** 4 inch H<sub>2</sub>O to 1 psi = 8 psi  
 2.5 to 499 psid = ~3.0x  
 500 to 1000 psid = 1500psi

† (see DSA5000 User Manual for complete list)

**Max Reference Pressure:** 250 psig (1724 kPa)\*\*

**Media Compatibility:** Gases compatible with silicon, silicone, RTV, gold, ceramic, epoxy, nylon, aluminum, and Buna-N  
 (Other O-Ring compounds available in All-Media builds including Viton and Neoprene)

## ORDERING INFORMATION

There are over 1000 different DSA configurations available. These configurations include:

- Gas or All-Media / Liquid builds
- Communication types; TCP/IP or iDDS
- Gas Measurement Valve configurations
  - Standard (16Px)
  - Dual Range (16DR)
  - True Differential (8DPx)
  - Individual Reference (16IR)
  - Dual Range, True Differential (8DDR)
  - Absolute (16APx)
  - Dual Range Absolute (16ADR)

- Fitting Kits
  - 0.040", 0.063", or 0.125" tubulations
  - 1/16" or 1/8" compression
  - 063 Quick-Couplers
  - None (Std. 5/16x24 Female threads)
- Quick Disconnect (QD) Header
- Optional Heater or Shock Mount Kit

To find the part number that matches the configuration needed, please visit [www.scanivalve.com/dsa5000](http://www.scanivalve.com/dsa5000) and use the DSA5000 part number generator form. Refer to the DSA5000 Manual for part number explanation.

\*Consult factory for custom ranges. Some configurations may dictate a reduction in accuracy

\*\* Elevated reference pressure measurements require special techniques and considerations. Consult factory for guidance.

## DIMENSIONS Inches [mm]

### Standard Base Configuration

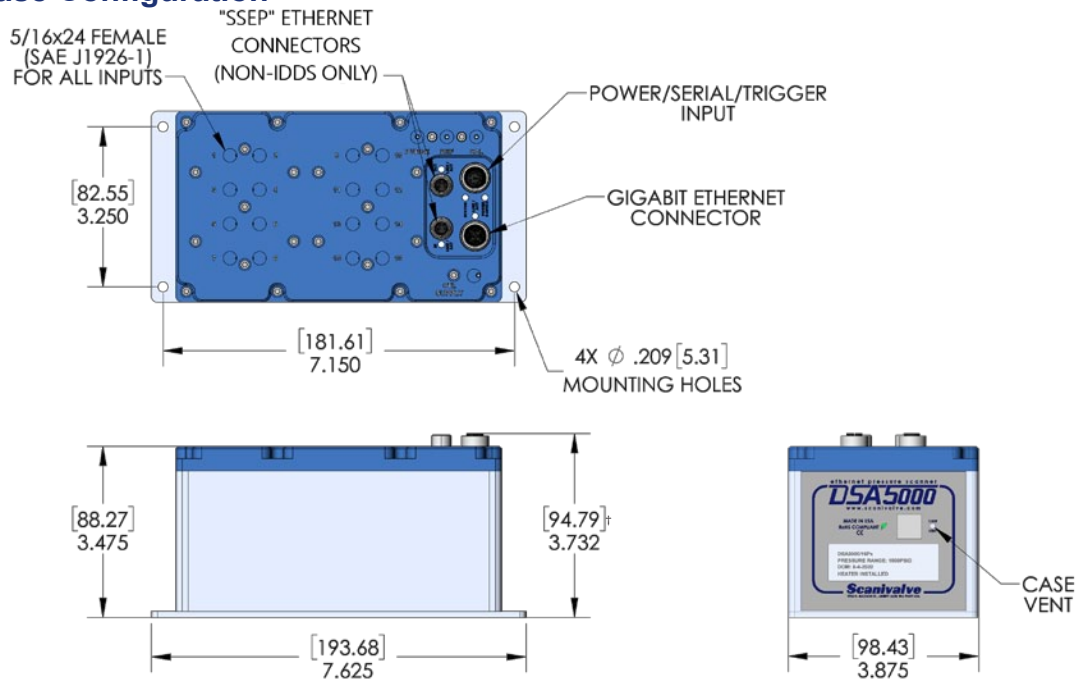

### Configured with optional Quick-Disconnect (QD) Header and Shock Mount Kit

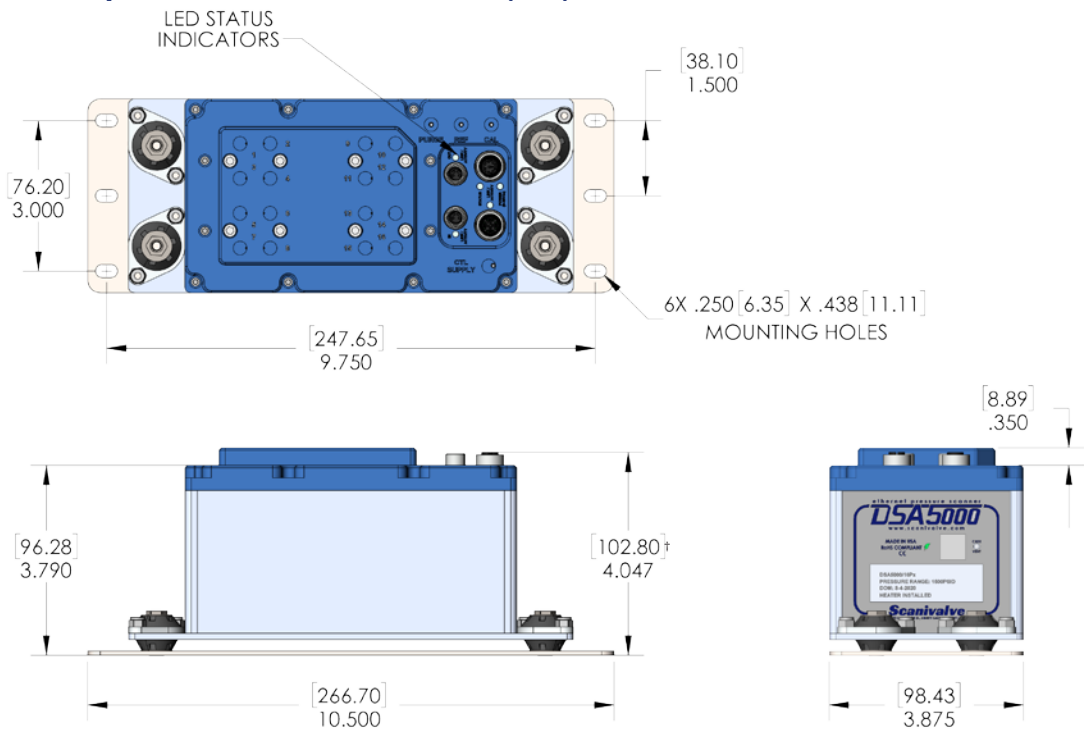

† Add 0.36" [9.1mm] for All-Media builds.

\*Each DSA5000 module comes with all mating electrical connectors.

\*\*Quick Disconnect (QD) Header and Shock Mount Kit are separate, individual options. QD Header not available on All-Media and some Gas builds.

**Scanivalve Headquarters**  
1722 N. Madson Street  
Liberty Lake, WA 99019  
Tel: 509-891-9970  
800-935-5151  
Fax: 509-891-9481  
e-mail: [scanco@scanivalve.com](mailto:scanco@scanivalve.com)

# Scanivalve

[www.scanivalve.com](http://www.scanivalve.com)

Printed in USA  
©2021 Scanivalve Corp.

2406

**Instrumentation  
Devices**

Instrumentation Devices Srl  
Via Acquanera 29 - 22100 COMO (Italy)  
ph +39 031 525 391- fax +39 031 507 984  
info@instrumentation.it - [www.instrumentation.it](http://www.instrumentation.it)