

## imc ARGUSfit Base Unit

Base unit for fast, compact and modular expandable measurement systems



### imc ARGUSfit – fast, compact and modular measurement systems

imc ARGUSfit is a compact modular system that allows the user to flexibly assemble fast data acquisition systems (DAQ). Both the base unit and the flexibly combinable measuring modules have independent housings which are connected by a "click" mechanism (no tools required) to form a DAQ system. This modularity includes not only measurement amplifiers but also interface modules such as for CAN bus.

imc ARGUSfit covers the entire frequency range of physical measurement applications with a total sampling rate of up to 5 MS/s and channel rates of up to 500 kSample/s, depending on the module type. Various such measurement modules for common signals and sensors are available and more will be released in the future.

In addition, interface modules can be added to integrate common field and vehicle buses such as CAN FD into the data acquisition and to exchange measurement data via these communication standards.

The system achieves particular flexibility by extending modularity even to decentralized topologies. The internal ARGUS high-speed system bus can be converted to fiber optic cables by means of a media converter extension module in order to integrate spatially distributed module blocks.

imc ARGUSfit also provides complete integration of the imc CANSASfit module series for slower channels, e.g. for temperature measurement: while fast imc ARGUSfit modules are docked to the bottom (right side) of the imc ARGUS base (high-speed system bus), imc CANSASfit modules can be clicked onto the top (left side). Such CANSASfit modules (CANFT) are likewise internally connected with power and CAN bus and are fully supported and integrated by the software as a uniform system. Finally, CANFT modules can even be installed in distributed topologies and connected via CAN-cable to the CANSAS-Interface of the base unit, provided on a dedicated LEMO.0B terminal.

The resulting DAQ system is networked by Ethernet and configured via a connected PC. In measurement mode, the PC can then serve as a sink for recorded data (continuous "streaming").

In stand-alone operating mode, the PC is not even required and the measurement data can also be stored on removable microSD flash memory. Live measurement data can already be pre-processed or evaluated by onboard realtime analyses (imc Online FAMOS). This applies to stand-alone mode, too. Typical analysis functionalities and applications include limit value monitoring, min./max. statistics, digital filters, spectral analysis, order analysis, classification and much more.

Multiple DAQ systems of the imc ARGUSfit series as well as other imc data logger and measurement systems can be interconnected via Ethernet. This allows to operate very large and multi-channel setups in which different imc device series work together uniformly and fully synchronized. The Ethernet interface can then be used for communication and data exchange as well as for absolute time synchronization of the entire system (via NTP).

### At a glance:

- Very compact, high-performance data acquisition system (DAQ)
- Particularly flexible: modular system without mainframe
- Click mechanism: connects modules electrically and mechanically
- Modularity for both analog amplifiers and digital interface modules
- Decentralized installations supported via fiber optic cable for high-speed system bus
- imc ARGUSfit amplifiers for almost any physical sensor and signal type
- High channel rates (and bandwidths) and up to 5 MSample/s total system data rate
- Multiple individual channel sampling rates
- Integrated real-time analysis through built-in imc Online FAMOS
- Full integration of imc CANSASfit
- Combination with all imc system families and synchronous acquisition of thousands of channels
- Comfortable operation with uniform and modern imc STUDIO software for all imc systems.

### imc ARGUSfit: Modules and the system

imc ARGUSfit complete DAQ systems are built around a base unit and can be composed of a number of imc ARGUSfit amplifier and interface modules (bottom/right), imc CANSASfit modules (top/left). In addition to the mechanical connection, the click connectors provide a backbone for power supply, data transfer via system bus or CAN bus, trigger, synchronization and fully integrated operation.

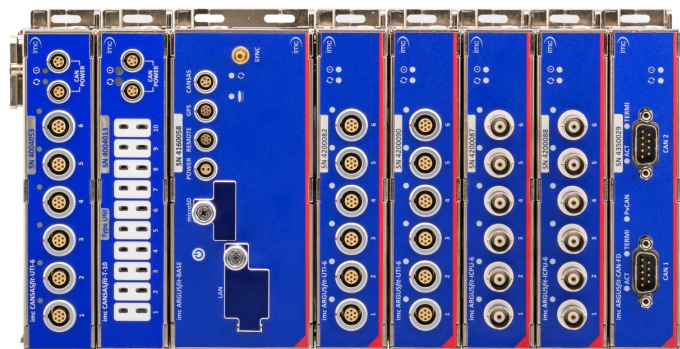

For expansion to decentralized distributed topologies, the system bus can be converted to fiber optic cables by means of a clickable fiber converter module. Furthermore, additional imc CANSASfit modules can also be connected via an additional CAN bus cable.

A battery buffered UPS module is available to compensate short term power failures such as with automotive applications that need to include the startup process (cold-cranking) or start-stop functions in the measurements.

### imc Online FAMOS

imc Online FAMOS is a powerful extension, included in every imc ARGUSfit DAQ system as a standard without any additional license required. It offers a variety of real-time functions for measurement data pre-processing executed on the processor of the base unit. This means that analysis results are available immediately and also independently of the PC. Such analysis can also yield significant data reduction and thus reduce the amount of data to be exchanged between the DAQ system and the PC. The results are available in imc STUDIO as virtual channels.

### Software minimum requirements

Operation of the imc ARGUSfit system requires operating software of the following group: imc STUDIO 2023 R3.

### Dimensions

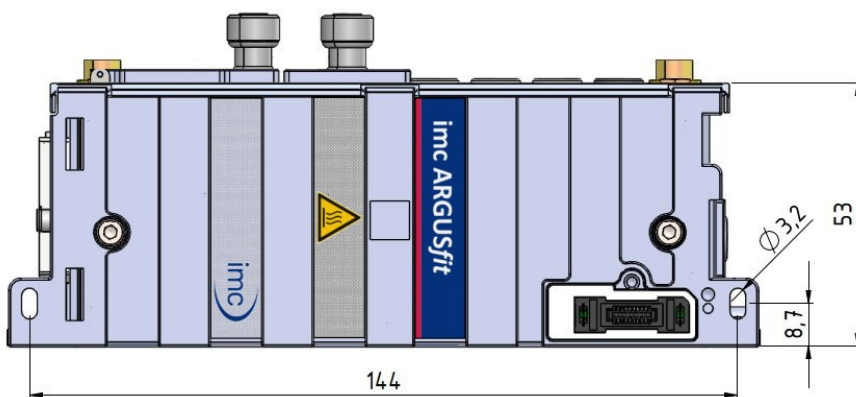

Base unit shown in standard operating position (terminal connections upwards).

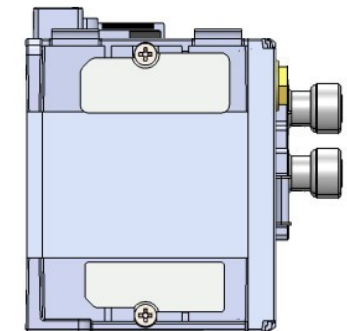
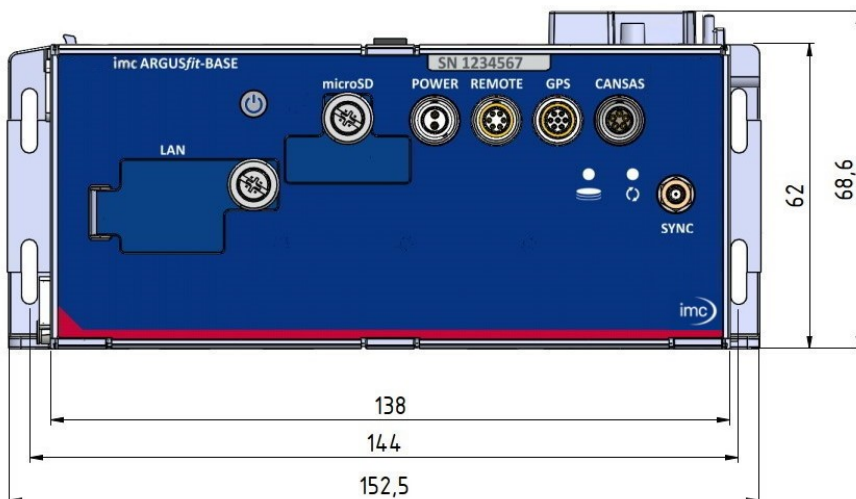

left module panel with parking position for the covers of the module connectors

### Overview of the available variants

Order Code	properties	article no.
ARGFT-BASE	high speed, compact and modular measurement system	11400200

### Included accessories

Power supply and connectors		
Order Code	properties	article no.
ACC/AC-ADAP-24-60-0B	AC/DC power adaptor: 24 V, 60 W, connector: LEMO.0B 2-pin	13500246
ACC/POWER-PLUG3	DC-power connector (plug for power socket)	13500033
Documents		
Getting started with imc ARGUSfit (one copy per delivery)		
Device certificate		
Miscellaneous		
1x Ethernet network cable with latch protection (uncrossed, 2 m)		

### Optional accessories

Power supply: cables and connectors		
Order Code	properties	article no.
ACC/CABLE-LEMO-0B-BAN-2M5	Supply cable for ARGUSfit BASE (LEMO.0B.302), Banana terminals, 2.5 m	13500276
ACC/CABLE-LEMO-LEMO-2M5	Connection cable for CANSASfit modules, 2 x LEMO.0B.305, 2.5 m Use of Power-via-CAN on base unit: supply of CANFT via ARGFT-BASE	13500229
ACC/CABLE-LEMO-LEMO-PWR0B-2M5	Connection cable for CANSASfit modules, 2 x LEMO.0B.305, 2.5 m Power-via-CAN not used on base unit: power feed for CANFT via LEMO.0B.302 female (for ACC/AC-ADAP-24-60-0B)	13500429
ACC/CABLE-LEMO-LEMO-PWR-2M5	Power splitter adapter for CANSASfit connection cable, 2 x LEMO.0B.305 (male & female), 0.5 m Power-via-CAN not used on base unit: power feed for CANFT via banana terminals. To be used in conjunction with 13500229	13500324
ACC/REMOTE-0B	connector for remote	13500050
FiberConverter		
ARGFT/FIBER-CONVERTER-SET	Media converter for the ARGUS system bus Includes: 2 converter modules, 2x SFP+ transceiver, 5 m fiber optic cable, AC/DC power adaptor and a power plug	11400225
microSD storage media		
ACC/MICROSD-512GB-ET	microSD Flash memory card 512 GB	135000xx
ACC/MICROSD-256GB-ET	microSD Flash memory card 256 GB Only microSD memory cards tested by imc may be used, as these have been specially qualified by us for our high data rate of 5 MS/s.	13500042
Miscellaneous		
GPS-receiver (with LEMO.0B connector)		
Mounting accessory (magnetic mounting and set for Top-hat rail)		

## Technical Specs Base Unit ARGFT

Terminal connections		
Parameter	Value	Remarks
PC / network Ethernet TCP/IP ("LAN")	RJ-45 1000BASE-TX (1 GBit/s) 100BASE-TX (100 MBit/s)	PC/network, synchronization fix and dynamic IP address protocol: IPv4
Flash storage ("microSD")	microSD slot	with protection cap
Internal WLAN adaptor	2 antennas IEEE 802.11g/n/ac Dual Band (2.4 / 5 GHz)	optional (in preparation)
Synchronization ("SYNC")	SMB	IRIG-B, isolated
External GPS module ("GPS")	LEMO.0B (7-pin)	available as accessory; software support in preparation
Remote control ("REMOTE")	LEMO.0B (6-pin)	remote power on/off
Power ("PWR")	LEMO.0B (2-pin)	compatible to LEMO.EGE.0B.302 suitable plug FGG.0B.302
imc CANSASfit Interface ("CANSAS")	LEMO.0B (5-pin)	connection of distributed imc CANSASfit modules: Power supply provided by base unit (Power-via-CAN, max. 1 A)
Module connector	Click connection (with covering caps)	mechanical connection, common DC power supply, system bus for imc ARGUSfit modules, interface for imc CANSASfit modules
Power supply		
Parameter	Value	Remarks
Input supply voltage	10 V to 50 V DC	
Power-on threshold (typ.)	≥9.5 V	min. input voltage required for power-on (no load)
Shutdown threshold (typ.)	≤8.5 V	input voltage at which the automatic shutdown is triggered (microSD data backup secured by internal buffering)
Power consumption	3.3 W (typ.) 3,1 W (typ.) @ 12 V DC 3,6 W (typ.) @ 48 V DC	plus 2 % / 10 K
Isolation	60 V	against housing (CHASSIS)
AC/DC power adaptor	110 V to 230 V AC	external adaptor 24 V / 60 W included in delivery

<b>Max. number of modules for direct coupling (block size with click mechanism)</b>		
<b>Parameter</b>	<b>Value</b>	<b>Remarks</b>
Compatible modules	imc ARGUSfit (ARGFT) imc CANSASfit (CANFT)	simultaneous operation of imc ARGUSfit and imc CANSASfit modules supported
Max. number of modules	max. n ARGFT modules + max. 8 CANFT modules	analog and fieldbus interface modules; n modules see Excel power configurator
<b>Pass through power limits for directly connected modules (click mechanism)</b>		
<b>Parameter</b>	<b>Value</b>	<b>Remarks</b>
Max. current	5 A  60 W at 12 V DC 120 W at 24 V DC	at 55 °C current rating of click connector to ARGFT modules respectively CANFT modules typ. DC vehicle voltage AC/DC power adaptor or installations
<b>Total supply power fed in at the ARGUS-BASE (via LEMO.0B, "CANSAS")</b>		
Max. current	5 A  60 W at 12 V DC 120 W at 24 V DC	at 55 °C current load capacity of the LEMO and internal elements. Total power of ARGFT-BASE and docked ARGFT and CANFT modules typ. DC vehicle voltage AC/DC power adaptor or installations
<b>UPS and Data integrity</b>		
<b>Parameter</b>	<b>Value</b>	<b>Remarks</b>
Autarkic operation	✓	Stand-alone data acquisition operation (Auto-start) without PC connection required
Auto data-saving upon power outage	✓	internal power buffering (UPS) to ensure data integrity with "auto-stop" auto-stop of measurement, data storage and automatic shutdown
UPS	integrated	Super-Caps
Charging time of the Super-Caps	<TBD s	minimum required active operation for full UPS functionality
UPS coverage	ARGFT base unit	no buffering of directly connected modules
UPS delay	0 s	"buffer-time constant": required duration of a continuous outage that will trigger auto shutdown procedure fixed parameter: cannot be changed in the device configuration!

Operating conditions		
Parameter	Value	Remarks
Operating environment	dry, non corrosive environment within specified operating temperature range	
Ingress protection class	IP50	with correctly mounted covers over both module connectors
Pollution degree	2	
Operating temperature range	-15 °C to +55 °C	without condensation
Shock- and vibration resistance	IEC 60068-2, IEC 61373 IEC 60062-2-64 category 1, class A and B MIL-STD-810 Rail Cargo Vibration Exposure U.S. Highway Truck Vibration Exposure	
Extended shock- and vibration resistance	upon request	specific tests or certification upon request
Dimensions (L x W x H)	153 x 62 x 53 mm	including mounting flanges and click mechanism, see mechanical <a href="#">drawings</a> <sup>3</sup>
Weight	0.5 kg	

Storage, signal processing		
Parameter	Value	Remarks
Removable flash storage	micro SD	recommended media available at imc; the specified operating temperature range of the media is relevant; Only microSD memory cards tested by imc should be used, otherwise performance or data may be degraded.
Typ. supported transfer rates (write) to microSD	10 channels at 500 kHz 50 channels at 100 kHz	guaranteed with imc qualified media (256 GB), only. Test conditions: data transfer to PC not activated, no additional OFA channels
Interval memory mode	✓	cyclical termination of the measurement data on mass storage medium
Extensive real-time analysis and control functions	✓	imc Online FAMOS included in standard delivery

Data acquisition, trigger		
Parameter	Value	Remarks
Max. aggregate sampling rate	5 MS/s	sum of sampling rates of all active channels
Channel individual sampling rates	selectable in 1–2–5 steps	max. 500 kSample/s, depending on ARGFT module
Number of sampling rates measurement channels	arbitrary	can be used for all hardware-bound channels, such as analogue channels, simultaneously in one configuration
Number of sampling rates fieldbus channels	arbitrary	
Number of sampling rates virtual channels	arbitrary	further rates generated by imc Online FAMOS (e.g. by means of reduction)
Intelligent trigger functions	✓	e.g. logical combination of multiple channel events (threshold, transition) to create triggers that start and stop acquisition of assigned channels
Multi triggered data acquisition	✓	Multi-shot (with automatic re-arming of the measuring system). A global device trigger with configurable start and stop condition.
Multi trigger	max. 8	independent trigger machines with channel assignment start/stop, assign channels as desired
Trigger definitions	AND/OR combinations of events	events: e.g. threshold value, edge, range
Number of event calculations	analog: 1 per module fieldbus: 8 per module	
Number of events used	64 used per system 8 per trigger machine	events can trigger multi-trigger

Maximum channel count per device		
Parameter	Value	Remarks
Active channels within a systems...	1000	active channels of the current configuration: Total number of analog and virtual channels, as well as monitor channels, if any.
...of which active analog channels	1000	active analog channels of the current configuration (sum of primary channels + monitor channels)
Prozess vector variables	2048	Single value variables, each containing the last measured values. A process vector variable is automatically created for each channel.
For fieldbus data as dump	any number of channels	within the non-decoded dump data



Monitor channels		
Parameter	Value	Remarks
Monitor channels	for all channels of the type: analog	derived from primary channel with pre-processing function, independent of imc Online FAMOS (processed on the amplifier modules)
Pre-processing for Monitor channels	reduction AAF RMS Minimum Maximum	each with a reduction factor or block size R selection 1 out of n: resampling resampling with adjusted low pass filter RMS over block size R statistics over block size R
Reduction factor R	2 .. 10.000.000 individually selectable	block size or resampling for the processing functions

Synchronization and time base: single device without external synchronization			
Parameter	Value (typ.)	min. / max.	Remarks
Accuracy RTC		±50 ppm  1 µs (1 ppm)	not calibrated (standard devices), at 25 °C  calibrated devices (upon request), at 25 °C
Drift	±20 ppm	±50 ppm	-15 °C to +55 °C operating temperature
Ageing		±10 ppm	at 25 °C; 10 years

External synchronization			
Parameter	IRIG-B	NTP	PTP (in preparation)
Supported formats	B002, B006	Version ≤4	Version 2
Precision	<1 µs	<5 ms after approx. 12 h <sup>1</sup>	<1 µs
Jitter (rms) <sup>2</sup>	<100 ns	---	<100 ns after 2 min
Input connection	SMB "SYNC" (isolated)	RJ45 "LAN"	RJ45 "LAN"

Synchronization via multiple devices with IRIG-B (Master/Slave)			
Parameter	Value (typ.)	min. / max.	Remarks
Common mode SYNC isolated		max. 50 V	BNC socket: isolated; for reliable operation even with different voltage level (ground loops).
Voltage level		5 V TTL level	
Input impedance		20 kΩ	

- 1 Max. value, concerning the following condition: first-synchronization
- 2 Statistical mean variation. Also dependent on signal quality with IRIG-B (e.g. direct connection to imc master device) respectively the specific network configuration with PTP (e.g. point-to-point connection via PTP-capable network switch such as imc NET-SWITCH-5).